

Red Head

Brass, LLC



Proudly
MADE IN THE USA
Since 1972

Contents

Couplings

<i>Quality Commitment in Aluminum Couplings</i>	2
<i>Red Head Specification for Aluminum Couplings</i>	2
Aluminum Expansion Ring Couplings	3
<i>Quality Commitment in Brass Couplings</i>	4
<i>Red Head Specification for Brass Couplings</i>	4
Brass Expansion Ring Couplings	4
Booster Couplings	5
Kwik-Tach Reattachable Couplings	6
Rib-Lok Suction Hose Couplings	6
Grooved & Threaded Reattachable Shanks and Mending Sleeves	7
Oil & Gas/Big Water Couplings and Sleeve	7A
Oil & Gas/Big Water Coupling and Adapters	7B
<i>Quality Commitment in Storz Couplings</i>	8
<i>Red Head Specification for Storz Couplings</i>	8
Aluminum Storz Couplings	9

Adapters

<i>Quality Commitment in Aluminum Adapters</i>	10
<i>Red Head Specification for Aluminum Adapters</i>	10
Aluminum Adapters	10-12
Brass Adapters	13
<i>Quality Commitment in Storz Adapters</i>	14
<i>Red Head Specification for Storz Adapters</i>	15
Aluminum Storz Adapters	14-15

Caps and Plugs

Threaded Aluminum and Brass	16
British Instantaneous and Cam & Groove	16
Long Handle Caps	17
Storz Caps	17

Elbows

Threaded Aluminum and Brass	18
Storz Elbows	18

Wyes and Valves

Aluminum Plain Wyes	19
Aluminum Wyes	19
Forestry and Leader Line Non-Locking Gated Wyes	19
Hydrant Gate Valves	19

Wrenches

<i>Quality Commitment in Wrenches</i>	20
Spanner Wrenches	20
Adjustable Hydrant Wrenches	21
Holder and Wrench Sets	21
Storz Wrenches, Holders, and Wrench Sets	22

Gauges

<i>Quality Commitment in Gauges</i>	23
Threaded Line Gauges	23
Threaded Cap Gauges	23
Storz Line and Cap Gauges	23

Expanders

Brute X-Pander and Brute Model 2	24
Expansion Units	25
Hose Cutters	25

Dry Hydrant and Water Delivery Systems

<i>Quality Commitment in Dry Hydrant Systems</i>	26
Maxi-Flow Dry Hydrant Elbows, Caps, Plugs, and Swivels	26
Dry Hydrant Underwater Strainer and Supports	27
Maxi-Flow Power Jet Siphon	27
Tank Fill Line Adapter	27
Maxi-Flow Lo-Level Strainers	27

Mounting Plates

Threaded Male and Female Mounting Plates	28
Storz Mounting Plates	28
Kwik-Tach Mounting Plates	28

Parts and Accessories

Gaskets	29
Expansion Rings and Expansion Ring Removal Tool	29
Bearings, Plugs, and Camlock Repair Kits	29
Basket and Adapter Strainers	29
Lam-n-Sole Safety Insoles	29

Nozzle Tips and Discharge Pipes

Deluge Tip and Stream Straightener	30
Discharge Pipes	30
Stacked Tips	30
Smooth Bore Tips	30

Hy-D

Hy-D	31
----------------	----

Made in USA Checklist

Checklist	32
---------------------	----

FAQs

Made in USA	32
Thread Charts	33
FAQs	34-35

This edition of our catalog places special emphasis on "Made in USA" and what is required to meet this standard. As we continue to hear about product failures and quality deficiencies in imported products, it has become increasingly important to know, not only where the final product is made, but what materials go into the product. All of the products made by Red Head Brass are made from extrusions, forgings and castings produced at US facilities. The final product is only as good as the raw material that goes into it.

The Federal Trade Commission (FTC) is charged with preventing deception and unfairness in the marketplace. With some exceptions, there is no law requiring that products sold in the US be marked or labeled *Made in USA*. However, manufacturers and marketers who choose to make this claim must comply with the FTC's *Made in USA* Policy. The policy applies to products, labeling and advertising such as catalogs, websites and other promotional materials. Red Head Brass products are *Made in USA*.

The FTC Policy requires that, for a product to be called *Made in USA*, the product must be "all or virtually all" made in the US. The FTC defines "all or virtually all" to mean that all significant parts and processing that go into the product must be of US origin and that the product contain no or negligible foreign content. According to this "all or virtually all" standard, manufacturers and marketers cannot indicate that a whole product line is US made ("Our products are made in USA," or "Made in US," or "U.S.A.") when only some products in the product line are made in the US. Likewise it cannot be implied, by a trademark or company name, for instance.

This FTC requirement should not be confused with the *Buy American Act*. This Act is often called for in US government procurements and requires that a product have 50 percent or more of US made content. If the products are identified as *Made in USA*, the FTC Policy applies.

We have provided a checklist on page 32 of this catalog of how Red Head Brass meets the "all or virtually all" requirement required by the FTC.

Red Head Brass quality differences do not end with *Made in USA*. While competitors will have an extra charge for features such as hardcoat or bearing connections for swivels, these features are standard on Red Head products. As our competitors take shortcuts and use gimmicks that reduce the quality and safety margin of their products, we continue a no compromise stance on quality...and safety. Compare metal wall thickness. Are the Storz products made from forgings produced at a US forging facility, or import forgings or lower quality castings that do not meet the DIN standard? Are swivels attached utilizing stainless steel ball bearings or aluminum roller bearings on larger fittings? Are the aluminum products hardcoat anodized to provide additional wear and corrosion protection?

For over 40 years, Red Head Brass has been the industry leader in quality couplings and fittings and we thank you for your many years of support. Please continue to patronize the outstanding distributors that make up the Red Head Brass Authorized Distributor network. They can be located by visiting our website at www.redheadbrass.com. Our pledge is to continue to provide you with the products you deserve...simply the best...and Made in the USA.

Thanks again for your business.



To order call 800-321-3501

Couplings

Made from 6061-T6 aluminum seamless extrusions.

Meets ASTM B-221.

Provides strength to meet Federal Spec A-A-59227A - Couplings shall not distort, bind, or become inoperative when subjected to a 3000 pound radial compression load as specified in 3.4.4.

The Red Head Brass Commitment to Quality and Safety in Aluminum Couplings

All Red Head aluminum couplings are Hardcoat Anodized per MIL-A-8625 Type III, Class 1. No dyes or coloring are used. Hardcoat is a hard, dense coating formed by converting the surface of the aluminum alloy into a hard aluminum oxide. This process provides the completed part with a hardened surface that resists corrosion, abrasion, and reduces electrolysis. It also prevents excessive wear on the threads. Complies with NFPA 1963, 4.12 Corrosion Resistance.

NO PLAIN ANODIZE OR POWDER COATED FINISHES!!

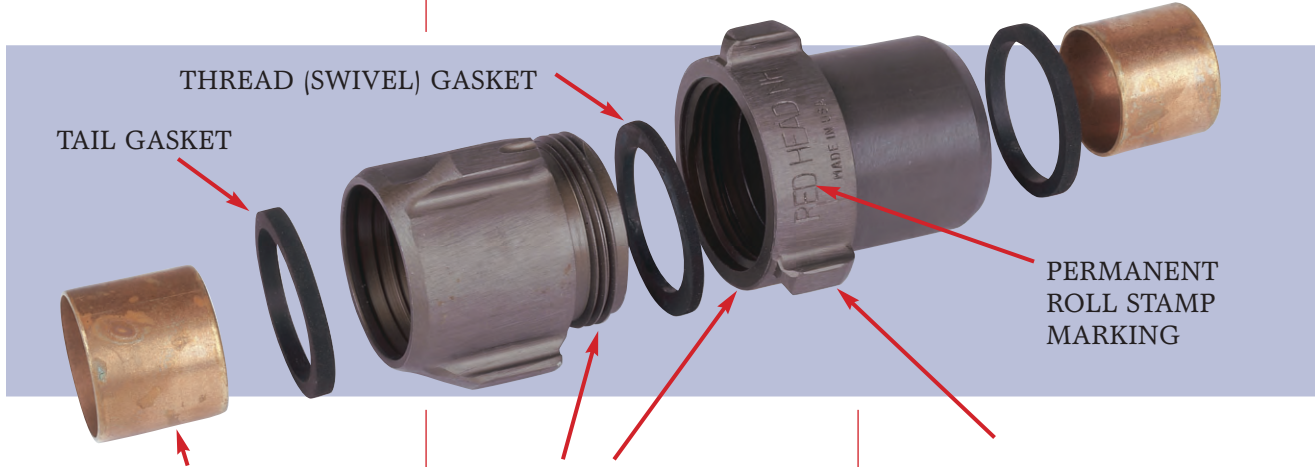

Expansion Rings included with each coupling. Made from seamless soft anneal red brass tubing, UNS 23000 for maximum expansion without danger of breaking. Chamfered edge prevents cutting of hose.

A-A-55535 - The rings shall be free from scale, grooving, indentations, cracks, scores, dents, and burrs. The end shall be round and smooth.

Threads conform to the following specifications, including a blunt start first thread known as the Higbee located in line with the Higbee indicator on the lug.

- Federal Handbook H28/10
- USDA 5100-190 C Tables 1 - 4
- NFPA 1963 5.1 thru 5.6.4
- UL 236 8.1 thru 8.2

Swivels are attached as follows:

1" thru 2 1/2" with 6061-T9 aluminum piston rings.

3" & 3 1/2" with #316 stainless steel ball bearings.

4" thru 6" with 6262-T9 aluminum roller bearings.

NO PLASTIC BEARINGS!!

The above construction allows compliance with the following:

A-A-59227A 3.4.1 - Couplings shall withstand a hydrostatic pressure of 1000 PSI.

A-A-59227A 3.4.3 - Couplings shall not be mechanically damaged at their thread or swivel connection or separated from the hose when a pull load of 2000 pounds per each inch of hose diameter is applied.

NFPA 1963 4.9 - Couplings shall be capable of being dropped up to 6 feet (3 times) without deformation or damage.

Meets low lead requirements.

Permanent roll stamp marking. Part identification is stamped into the aluminum prior to hardcoat finish. Complies with USDA 5100-190 C 3.4.

Lathe cut synthetic or EPDM gaskets included with each coupling.

NFPA 1963, 7.1 - Each coupling shall be equipped with a resilient thread gasket with a durometer of 70 +/-5, Shore A.

NFPA 1963, 7.3 - Each coupling shall be equipped with a resilient tail gasket with a durometer of 60 +/-5, Shore A.

RED HEAD SPECIFICATIONS: Hose Couplings shall be fabricated from seamless extruded 6061-T6 aluminum and hardcoat anodized per MIL-A-8625 Type III, Class 1. Male end lugs shall have "LA Taper". Threads shall be blunt start Higbee cut with indicators on adjacent lugs. Part identification shall be permanent and stamped prior to hardcoat. Swivel attachment must be metal rings or bearings, not swaged. Gaskets shall be lathe cut ozone free EPDM or synthetic rubber. Expansion rings must be smooth and well rounded soft anneal seamless red brass per UNS 23000. Couplings and components must meet the requirements of NFPA 1963.

7700 Styles Aluminum Heavy Duty Expansion Ring Couplings

Available Sizes:
1" thru 6"

Configurations:

- 1" - Two rocker lugs on male and swivel.
- 1½" thru 3½" - Three rocker lugs on male and swivel.
- 4" thru 6" - Four rocker lugs on male and swivel.

Style 7715 (1½") and 7725 (2½") are **FM Approved**.

Meets **A-A-59227A, Type A, Style 1, Type B (WW-C-621G) and A-A-59226A (ZZ-H-451G)** latest revision.



RHQK Styles Quick Connect External Lug Forestry Expansion Ring Couplings

Available Sizes:
1½" connecting face
for either 1" or 1½"
forestry hose

Features:

- Made from aluminum forgings.
- External lugs for faster action in a demanding field where quick connection counts.
- No threads to damage, hang up, or seize... complete reliability.
- ULC listed 1½".

Meets requirements of **ULC-S551**.



F Styles USDA Forestry Couplings

Available Sizes:
1", 1½" and 2½"

Configurations:

- 1" - Two rocker lugs on swivels only.
- 1½" and 2½" - Three rocker lugs on swivel only.

Meets **USDA Forest Service Spec 5100-108**.



R Styles Aluminum Rack Hoses Couplings

Available Sizes:
1½" Rack Hose

Configuration:
Two rocker lugs
on swivels only.



BIT Styles Aluminum British Instantaneous Hose Couplings

Available Sizes:
2½" only

**Working
pressure of
15 Bar or
218 PSI.**

Configurations and features:

- All 2½" connections conform to the **BS 336 standard**.

Meets **BS-336**.



RHCE Styles Aluminum Cam & Groove Hose Couplings

Available Sizes:
1½", 2" and 2½"

Features:

Slim-line profile reduces drag and hang-ups. Handles and pins are 316 stainless steel. Face Seal gaskets are long lasting Buna-N.

Working pressure of 750 PSI.

Meets **A-A-59326B (Mil-C-27487)**.
Meets **ASTM F1122**.



The Red Head Brass Commitment to Quality and Safety in Brass Couplings

- All Red Head 5500 Styles couplings are made from cast red brass, **C84400 or C83600, ASTM B584 or ASTM B505**.
- Couplings in this series conform to Government Specifications **A-A-59227A, Type A, Styles 1 and 2, Type B (WW-C-621G)**; and **A-A-59614, Type III, Styles 7 and 8 (WW-C-624E)**.
- Lathe cut synthetic or EPDM gaskets included with each coupling.
- Expansion Rings included with each coupling. Made from **seamless soft anneal red brass tubing, UNS 23000** for maximum expansion without danger of breaking. **Chamfered edge** prevents cutting of hose.

A-A-55535 - The rings shall be free from scale, grooving, indentations, cracks, scores, dents, and burrs. **The end shall be round and smooth.**

NFPA 1963, 7.1 - Each coupling shall be equipped with a resilient thread gasket with a **durometer of 70 +/-5, Shore A**.

NFPA 1963, 7.3 - Each coupling shall be equipped with a resilient tail gasket with a **durometer of 60 +/-5, Shore A**.

Style 5500 *Cast Brass Heavy Duty Expansion Ring Couplings*

Available Sizes:
1½"
2"
2½"

Configuration:
Two rocker lugs on male
and swivel.



Style RX *Brass Rack Hose Couplings*

Available Sizes:
1½" only

Configuration:
Two rocker lugs
on swivel only.



RED HEAD SPECIFICATIONS: Hose Couplings shall be machined from cast red brass, alloy C84400 or C83600 ASTM B584 or ASTM B505. Male end rocker lugs shall be tapered to minimize snagging. Threads shall be blunt start Higbee cut with indicators on adjacent lugs. Part identification shall be permanent and stamped. Swivel attachment must be metal rings or bearings, not swaged. Gaskets shall be lathe cut ozone free EPDM or synthetic rubber. Expansion rings must be smooth and well rounded soft anneal seamless red brass per UNS 23000. Couplings and components must meet the requirements of NFPA 1963.

Red Head Brass offers a complete line of Bar-Way booster couplings in both aluminum and brass.

Style BW-A

Bar-Way Hole Type Aluminum Couplings

Available Sizes: 3/4", 1" and 1 1/4"

Configuration and Features:

- Hole type only.
- Design incorporates threaded insert into hose waterway. Shell covers hose end.
- Machined from lightweight 6061-T6 aluminum seamless extrusions.

Bar-Way aluminum booster couplings are **hardcoat anodized** per *MIL-A-8625 Type III, Class 1*.



Style BW-B

Style K-BW-B Chrome Plated Brass

Bar-Way Hole Type Brass Booster Couplings

Available Sizes: 3/4", 1" and 1 1/4"

Configuration and Features:

- Hole type only.
- Design incorporates threaded insert into hose waterway. Shell covers hose end.
- Available in chrome brass as *Style K-BW-B*.
- Brass booster couplings are machined from yellow brass rod *C36000 of ASTM B16*.



Booster Hose Installation Kit

Kit includes lubricant, key, wrench and clamp.

- Weight: 5 lbs.

Bar-Way Kit



To order call 800-321-3501

Couplings

Red Head quality can be found in all the couplings featured below. These couplings are made from **6061-T6 aluminum seamless extrusions...including the collars** on Kwik-Tach field reattachable couplings. **No plastic collars!!** Of course, all of the aluminum components are hardcoat anodized per *MIL-A-8625 Type III, Class 1*.

KWIK-TACH

Style KT
Style KT-LH
Threaded Reattachable Couplings for Rubber Covered and Lightweight Jacketed Hose

Available Sizes:
4", 5" and 6"

Configurations and features:

- Style KT - Rocker Lugs on male and female swivel.
- Style KT-LH and KT-399 - Rocker Lugs on male with long handles on female swivel.
- Reattachable in the field; requires only an Allen wrench to assemble or disassemble.
- KT and KT-LH Collars are assembled with $\frac{3}{8}$ "-16 socket head cap screw made of a high tensile alloy to *ASTM A574* with Zinc Yellow Dichromate coating to *QQ-Z-325, Type II*.
- KT-399 Collars are assembled with $\frac{1}{4}$ "-20 socket head cap screws made of **18-8 stainless steel**.

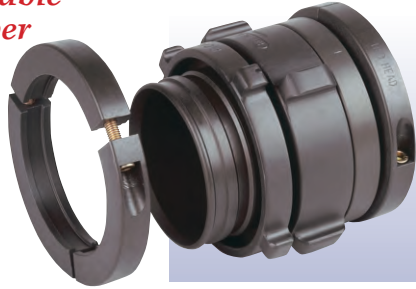

Style KT-399
Threaded Reattachable Couplings for Lightweight, Ribbed PVC Suction Hose



RIB-LOK

Style 399
Threaded Expansion Ring Couplings for Lightweight, Ribbed PVC Suction Hose

Available Sizes:
4", 5" and 6"

Configurations and features:

- Rocker Lugs on male and long handle female swivel.
- Complete with expansion rings and gaskets.



Style 299
Aluminum Long Handle Suction Hose Coupling

Style 19
Long Handle Female Only

Available Sizes:
2 1/2" thru 6"

Configurations and features:

- Long Handles are finger-gripped and canted for clearance.
- Sizes 2 1/2" thru 3 1/2" are assembled with **#316 stainless steel ball bearings**.
- Sizes 4" thru 6" are assembled with **6262-T9 aluminum roller bearings**.
- Complete with expansion rings and gaskets.



Style GS

Reattachable Grooved Shank Couplings

A lightweight aluminum grooved shank, easily installed, field repairable, and reattachable coupling. Designed for use with large diameter layflat hose, the coupling consists of a hose shank and a Red Head Brass segmented Kwik-Tach clamp collar. One end of the shank is machined to accept the mating collar. The opposite end has a machined groove. The clamp collar is easily assembled to the hose using a hex (Allen) wrench.

Available Sizes: 4" and 6"



Configurations and features:

- The Kwik-Tach clamp collar allows for re-tightening after initial hose pressurization.
- 4" thru 6" shanks and collar segments are machined from **6061-T6 aluminum seamless extrusions**.
- Shanks and collars are hardcoat anodized to **MIL-A-8625 Type III, Class 1**.
- Shanks have undulating diameters to provide for secure and leak proof hose attachment. Collar segment diameters are sized to match mating shank diameters and hose thickness.
- Collar segments are drilled and tapped on one end with a corresponding clearance hole on the opposite end.
- Outside collar diameters sized to provide added abrasion resistance for the hose and radiused to reduce hang-ups when dragging.
- Clamp Bolts are high tensile Alloy Steel per **ASTM A574** with Zinc yellow dichromate plating per **QQ-Z-325, Type II** for corrosion resistance. (Strength equivalent to Grade 9 Bolt).

Style TS

Reattachable Threaded Shank Couplings

- Same as Style GS except threaded end instead of a grooved end.
- Can be threaded into cam and groove adapter to create field reattachable fitting.



Style MEND

Reattachable Mending Sleeve

Available Sizes: 4", 5" and 6"

- Ideal for field repairs of large diameter hose.
- Shank and Kwik-Tach clamp collars are machined from **6061-T6 aluminum extrusions** and hardcoat anodized to **MIL-A-8625 Type III, Class 1**.
- Collars are assembled with 3/8-16 socket head cap screw made of high tensile alloy to **ASTM A574** with Zinc Yellow Dichromate coating to **QQ-Z-325, Type II** for corrosion resistance. (Strength equivalent to Grade 9 Bolt).

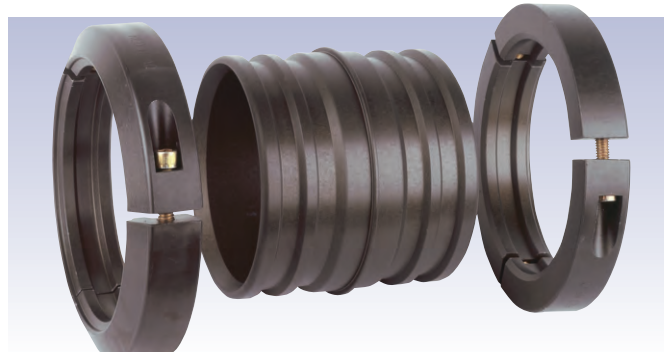

Style GS

Reattachable Grooved Shank Couplings

A lightweight aluminum grooved shank, easily installed, field repairable, and reattachable coupling. Designed for use with large diameter layflat hose, the coupling consists of a hose shank and a Red Head Brass segmented Kwik-Tach clamp collar. One end of the shank is machined to accept the mating collar. The opposite end has a machined groove. The clamp collar is easily assembled to the hose using a hex (Allen) wrench.

Available Sizes: 8", 10" and 12"

Configurations and features:

- The Kwik-Tach clamp collar allows for re-tightening after initial hose pressurization.
- Shanks and collar segments are machined from **6061-T6 aluminum seamless extrusions**.
- Shanks and collars are hardcoat anodized to **MIL-A-8625 Type III, Class 1**.
- Shanks have undulating diameters to provide for secure and leak proof hose attachment. Collar segment diameters are sized to match mating shank diameters and hose thickness.
- Collar segments are drilled and tapped on one end with a corresponding clearance hole on the opposite end.
- Outside collar diameters sized to provide added abrasion resistance for the hose and radiused to reduce hang-ups when dragging.
- Clamp Bolts are high tensile Alloy Steel per **ASTM A574** with Zinc yellow dichromate plating per **QQ-Z-325, Type II** for corrosion resistance. (Strength equivalent to Grade 9 Bolt)



Style TS

Reattachable Threaded Shank Couplings

Available Size: 8"

- Same as Style GS except threaded end instead of a grooved end.
- Can be threaded into cam and groove adapter to create field reattachable fitting.

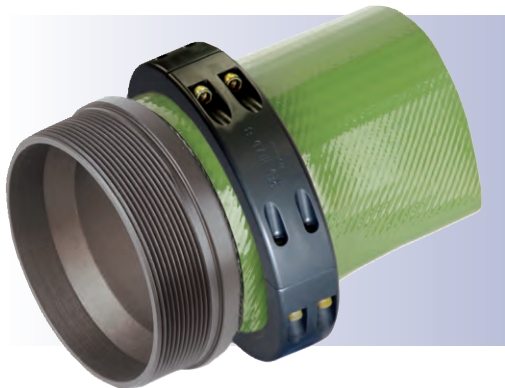

Style MEND

Reattachable Mending Sleeve

Available Sizes: 8", 10" and 12"

- Ideal for field repairs of large diameter hose.
- Shank and Kwik-Tach clamp collars are machined from **6061-T6 aluminum extrusions** and hardcoat anodized to **MIL-A-8625 Type III, Class 1**.
- Collars are assembled with 3/8-16 socket head cap screw made of high tensile alloy to **ASTM A574** with Zinc Yellow Dichromate coating to **QQ-Z-325, Type II** for corrosion resistance. (Strength equivalent to Grade 9 Bolt).

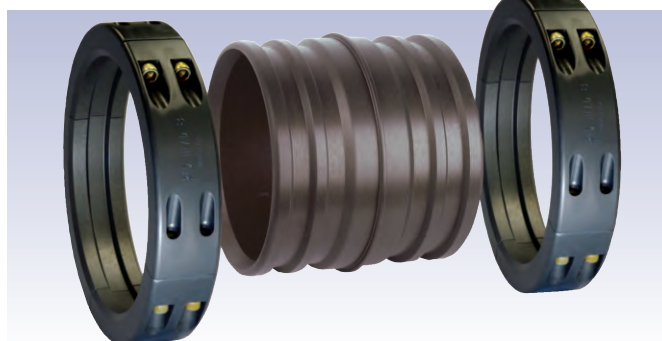

STYLE SKT QUICK CONNECT COUPLING

A lightweight, easily installed, field repairable, and re-attachable, quick connect coupling (aka Storz) to be used with 8" 10" & 12" diameter layflat hose (LDH). The coupling consists of a quick connect head, hose shank and a 4 segment bolted clamp collar easily assembled to the hose using a hex (Allen) wrench. The clamp collar allows for re-tightening after initial hose pressurization.

Available Sizes: 8", 10", and 12"

Configurations and features:

- Coupling head, shank, and collar machined from strong, **seamless extruded aluminum, Alloy 6061-T6**, for light weight.
- Hardcoat anodized per **MIL-A-8625 Type III, Class 1** for wear and corrosion resistance.
- Head equipped with external, spring return stainless steel locking lever to prevent unintentional disconnects. Head has visual indicators to show locked position.
- Equipped with Viton Storz-type Suction/Pressure Gasket for leakproof seal.
- Shank diameter sized for close fit with inside diameter of LDH. Shank has undulating diameters to provide for secure and leak proof hose attachment when used with the mating clamp collar.
- Collar sized to match mating shank diameters and thickness of hose .
- Each collar segment drilled and tapped on one end for 3/8"-16 bolts and clearance hole drilled on opposite end for 3/8" diameter bolts.
- Clamp Bolts, 2 per segment, high tensile Alloy Steel per **ASTM A574** with Zinc yellow dichromate plating per **QQ-Z-325, Type II** for corrosion resistance.(Strength equal to Grade 9 bolt).
- Collar outside diameter sized to provide added abrasion resistance for the hose. Ends radiused and tapered to reduce hang-ups when dragging.



Style SGS

Adapter – Storz to Grooved End

Available Sizes: 8", 10", and 12"

Configurations and features:

- Adapter combining the quick connect coupling head used in Style SKT above with the grooved end shank found in the Style GS.
- Components machined from **6061-T6 aluminum seamless extrusions**.
- **Hardcoat anodized** per **MIL-A-8625 Type III, Class 1**.



Style FS

Adapter – Storz to ANSI 150 Flange

Available Size: 8"

Configurations and features:

- Adapter combining the quick connect coupling head used in Style SKT above with an ANSI 150 Flange.
- Components machined from **6061-T6 aluminum seamless extrusions**.
- **Hardcoat anodized** per **MIL-A-8625 Type III, Class 1**.

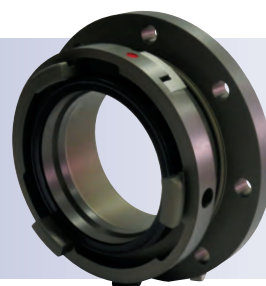

The Red Head Brass Commitment to Quality and Safety in Storz Couplings

Red Head's high quality Storz couplings have no peer. Our Storz heads up to 6" are forged as required by the DIN standards for firefighting applications...not cast. The tail pieces are made from extruded seamless aluminum...not castings or plastics. Collars are made from high strength aluminum extrusions...not cast. Review our quality below, and then insist on the best: Storz couplings from Red Head Brass.

Tail piece and collars made from 6061-T6 aluminum seamless extrusions.

Meets *ASTM B221*.

NO CAST OR PLASTIC TAILS OR COLLARS!!

All Storz Heads up to 6" are *forged* 6061-T6 aluminum to *Spec. SAE-AMS-QQ-A-367* and *ASTM B247*.

Complies with *DIN standards*.

NO CAST STORZ HEADS!!

Stainless Steel Lock Lever assembly configuration:

Lock Lever is an investment casting of 304 stainless steel *ASTM A743*.

Lock Lever Spring is 316 stainless wire passivated *AISI 316*.

Lock lever mounted with 18-8 stainless steel shoulder bolt.

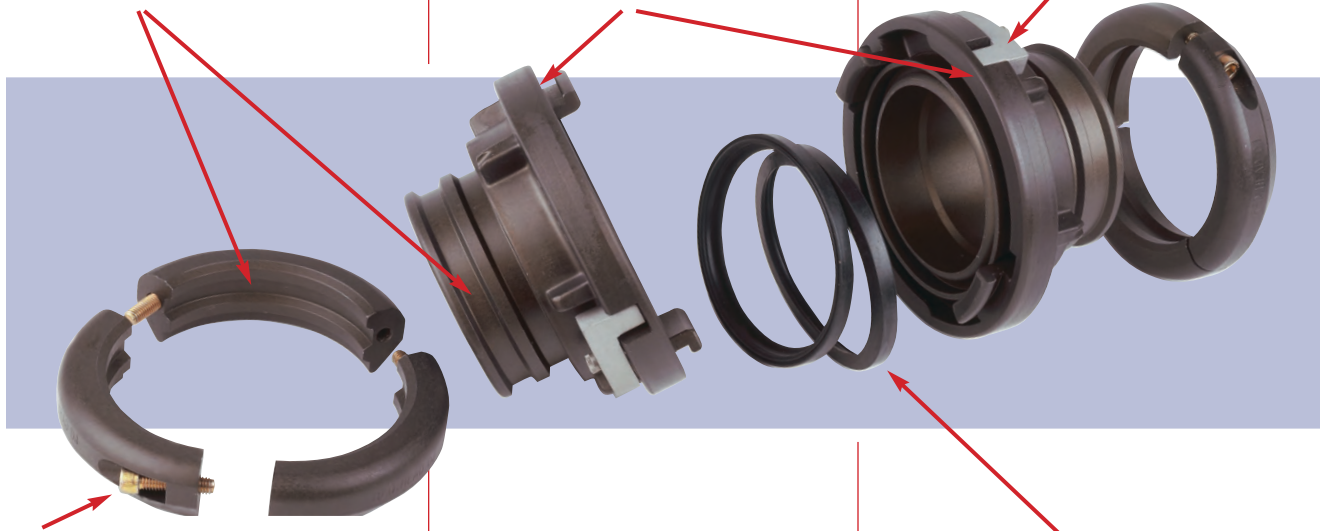

Collars are assembled with 3/8-16 socket head cap screw made of a high tensile alloy to *ASTM A574* with Zinc Yellow Dichromate coating to *QQ-Z-325, Type II*.

All aluminum components are **Hardcoat Anodized** per *MIL-A-8625 Type III, Class 1*.

High quality molded Storz gaskets made using **Buna-N material**. This material is resistant to most hydrocarbons, oils, gasoline, acids and greases.

RED HEAD SPECIFICATIONS: Aluminum Storz Hose Couplings shall consist of Storz coupling heads machined from forged 6061-T6 aluminum and coupling components fabricated from seamless extruded 6061-T6 aluminum. All aluminum components shall be hardcoat anodized per MIL-A-8625 Type III, Class 1. Part identification shall be permanent and stamped or forged prior to hardcoat. All 4", 5" and 6" coupling heads shall include a stainless steel external spring-loaded lock. Storz gaskets shall be molded Buna-N rubber.

For field reattachable couplings add: The couplings shall have a tail piece sized to match hose diameter and matching segmented, bolted clamp collars fabricated from seamless extruded 6061-T6 aluminum. Couplings and components must meet the requirements of NFPA 1963.

For expansion type couplings add: Swivel and tail gaskets shall be lathe cut ozone free EPDM or synthetic rubber. Expansion rings must be smooth and well rounded soft anneal seamless red brass per UNS 23000. Couplings and components must meet the requirements of NFPA 1963.

Style SKT

Available Sizes:
4", 5" and 6"

Configurations and features:

- Storz reattachable couplings for rubber covered, lightweight double jacketed or triple duty hose.
- Tapered design reduces hang-up when dragging.
- Reattachable in the field, requires only an Allen wrench to assemble or disassemble.
- When ordering, specify whether hose is rubber covered, lightweight double jacket or triple duty.
- Stainless steel lock levers on all Style SKT couplings.



Style SEX

Available Sizes:
1½" Storz (1½" and 1¾" hose) and 2½" Storz (2½" hose)

Configurations and features:

- Complete with expansion rings and gaskets.
- Tapered design reduces hang-up when dragging.
- Made of lightweight 6061-T6 seamless aluminum and forged heads.
- When ordering, specify hose bowl size.
- Special expansion unit required for assembly of 1½" and 1¾" hose.



Style S-299-L

Available Sizes:
4", 5" and 6"

Configurations and features:

- Storz coupling designed for use with hard suction hose.
- Tapered design reduces hang-up when dragging.
- Complete with expansion rings and gaskets.
- Stainless steel lock levers on all Style S-299-L couplings.



Adapters

The Red Head Brass Commitment to Quality and Safety in Aluminum Adapters

All aluminum adapters are not created equal. The Red Head Brass *quality advantage* is built into every aluminum adapter we sell. Look for the following features:

All Red Head aluminum adapters are **hardcoat anodized** per **MIL-A-8625 Type III, Class 1**. No dye or coloring is used. This process provides the completed part with a **hardened surface** that resists corrosion, abrasion, and reduces electrolysis. It also prevents excessive wear on the threads. Complies with **NFPA 1963, 4.12 Corrosion Resistance**.

NO PLAIN ANODIZE, PAINTED OR POWDER COATED FINISHES!!

Swivels are attached as follows:

1" thru 2" with **6061-T9 aluminum piston rings**.

2½" thru 3½" with **#316 stainless steel ball bearings**.

4" thru 6" with **6262-T9 aluminum roller bearings**.

NO PLASTIC BEARINGS!!

Made from **6061-T6 aluminum seamless extrusions**.

Meets ASTM B221.

Lathe cut synthetic or EPDM gaskets.

Permanent roll stamp marking. Part identification is stamped into the aluminum prior to hardcoat finish. Complies with **USDA 5100-190 C 3.4**.

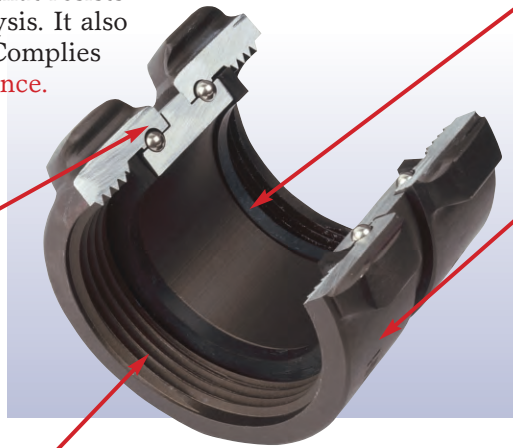

Threads conform to the following specifications, including a blunt start first thread known as the Higbee located in line with the Higbee indicator on the lug.

- **Federal Handbook H28/10**
- **USDA 5100-190 C Tables 1-4**
- **NFPA 1963 5.1 thru 5.6.4**
- **UL 236 8.1 thru 8.2**

Adapters with rocker lugs have:

- 2 lugs on sizes ¾" and 1"
- 3 lugs on sizes 1½" thru 3"
- 4 lugs on sizes 4" thru 6"

Style 35

Double Swivel Female

Available Sizes:
1" thru 6"



Style 36

Double Male

Available Sizes:
¾" x 1" thru 6"



Style 37

Rocker Lug Female by Male

Available Sizes: ¾" x 1" thru 6"

RED HEAD SPECIFICATIONS: Aluminum Adapters shall be fabricated from seamless extruded 6061-T6 aluminum and hardcoat anodized per MIL-A-8625 Type III, Class 1. Threads shall be blunt start Higbee cut with indicators on adjacent lugs. Part identification shall be permanent and stamped prior to hardcoat. Swivel attachment must be metal rings or bearings, not swaged. Gaskets shall be lathe cut ozone free EPDM or synthetic rubber. Adapters and components must meet the requirements of NFPA 1963.

Style 53 RL

Rocker Lug Swivel Female to Rocker Lug Rigid Female

Available Sizes:
1½" thru 6"



Style 54

Long Handle Swivel Female to Male

Available Sizes:
2½" thru 6"

Style 54RL

Rocker Lug Swivel Female to Male

Available Sizes:
1½" thru 6"



Style 56

Rigid Long Handle Female to Male

Available Sizes:
4" x 2½" thru 6" x 6"

Configurations and features:

- Ideal for changing hydrant or suction hose threads or sizes.

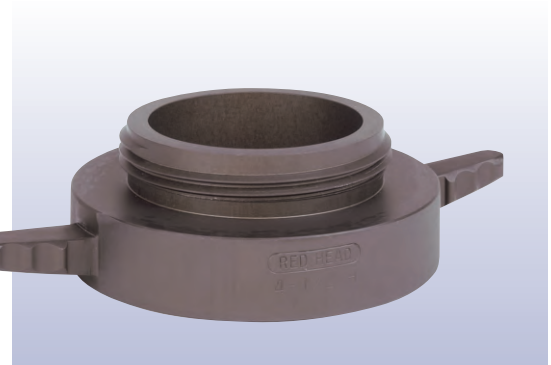

Style 57

Long Handle Double Swivel Female

Available Sizes:
2½" thru 6"

Configurations and features:

- Ideal for adapting male hydrant or suction hose threads to female hose thread.



Adapters

Style RHQK

Quick Connect External Lug Forestry Adapters

Available Sizes:
1½" connecting face x ¾", 1" or 1½" thread sizes

Configurations and features:

- External lugs for faster action, in a demanding field where quick connection counts.
- Red Head QK adapters are forged for heavy duty and dependability.
- ULC listed - 1½"
- Meets requirements of ULC-S551.

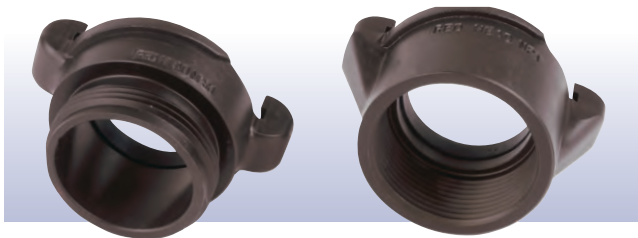

Style Cam and Groove

High Pressure Cam & Groove Adapters

Available Styles and Sizes:

Style A: Cam Male x Threaded Female
1½", 2", 2" x 1½" or 2½"

Style B: Cam Female x Threaded Male
1½", 2" or 2½"

Style D: Cam Female x Threaded Female
1½", 2", 2" x 1½" or 2½"

Style F: Cam Male x Threaded Male
1½", 2" or 2½"



Configurations and features:

- All Cam & Groove connections conform to [A-A-59326B \(MIL-C-27487\)](#).
- Handles and pins are **316 stainless steel**.
- **Working pressure of 750 PSI.**

Style 36HEX

Aluminum Hex Double Males

Available Sizes:
1", 1½" and 2"

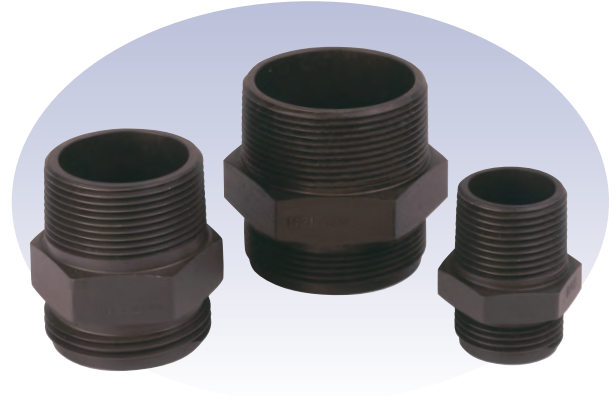

Style BIT

British Instantaneous Adapters



Available Styles and Sizes:

Style MF: BIT Male x Threaded Female
2½" BIT x 1½" thru 2½" THREAD

Style MM: BIT Male x Threaded Male
2½" BIT x 1½" thru 2½" THREAD

Style FF: BIT Female x Threaded Female
2½" BIT x 1½" thru 2½" THREAD

Style FM: BIT Female x Threaded Male
2½" BIT x 1½" thru 2½" THREAD

Configurations and features:

- All 2½" connections conform to the [BS 336 standard](#).
- **Working pressure of 15 BAR or 218 PSI.**

The Red Head Brass Commitment to Quality and Safety in Brass Adapters

Red Head Brass adapters are made of rugged brass castings of *Alloy C83600 ASTM B62* or *C84400* to *ASTM B584* or *ASTM B505 (QQ-C-390)* except where noted. Selected Hex style adapters made from *yellow brass rod* material to *C36000* to *ASTM B16*. All brass adapters are machined to the same high quality as our lightweight aluminum adapters.

Style BR35 *Double Swivel Female*

Available Sizes
1 1/2", 2 1/2" x 1 1/2" and 2 1/2"

Configurations and features:

- Available in Rocker Lug.
- 2 1/2" double female swivels are machined from **high quality forgings** of *Alloy C37700 ASTM B124 (QQ-B-626D)*.



Style BR37 *Rigid Female to Male*

Available Sizes:
1 1/2" x 3/4" thru 2 1/2" x 2 1/2"
in Rocker Lug.
1" thru 2 1/2" in Hex Style.

Configurations and features:

- Available in Rocker Lug and Hex Style.

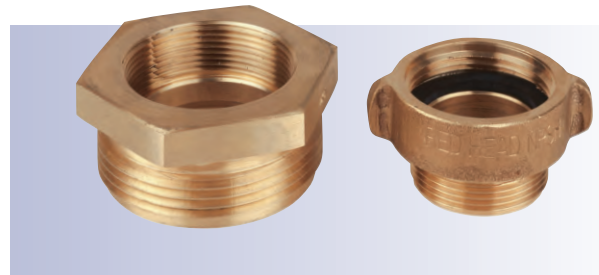

Style BR36 *Double Male*

Available Sizes:
1 1/2" or 2 1/2" in
Rocker Lug.
1" thru 2 1/2" in Hex Style.

Configurations and features:

- Available in Rocker Lug and Hex Style.



Style BR53 *Female RL Swivel to Rigid Female Hex*

Style BR54 *Female RL Swivel to Male Hex*

Available Sizes: 1 1/2" and 2 1/2"



The Red Head Brass Commitment to Quality and Safety in Storz Adapters

Quality and durability are constructed into every Storz adapter from Red Head Brass. Look for the features below and insist on the highest quality, safest Storz adapters available.

All aluminum components are **Hardcoat Anodized** per **MIL-A-8625 Type III, Class 1**.

NO PLAIN ANODIZE, PAINTED OR POWDER COATED FINISHES!!

Threads conform to the following specifications, including a blunt start first thread known as the Higbee located in line with the Higbee indicator on the lug.

- **Federal Handbook H28/10**
- **USDA 5100-190 C Tables 1-4**
- **NFPA 1963 5.1 thru 5.6.4**
- **UL 236 8.1 thru 8.2**

All swivels are attached with metal bearings.

Swivels are attached as follows:

2½" thru 3½" with #316 stainless steel ball bearings.

4" thru 6" with 6262-T9 aluminum roller bearings.

NO PLASTIC BEARINGS!!



High quality molded Storz gaskets made using **Buna-N** material. This material is resistant to most hydrocarbons, oils, gasoline, acids and greases.

Stainless Steel Lock Lever assembly on all 4", 5" or 6" Storz adapters.

All Storz heads are **forged 6061-T6 aluminum** to **SAE-AMS-QQ-A-367** and **ASTM B247**.

Complies with **DIN standards** which require that Storz heads must **be forged** when used in firefighting applications.

- **Lock Lever** is an investment casting of 304 stainless steel **ASTM A743**.
- **Lock Lever Spring** is 316 stainless wire passivated **AISI 316**.
- Lock lever mounted with **18-8 stainless steel shoulder bolt**.

Style S-36 Storz to Rigid Male

Available Sizes:
1½", 2½", 4",
5", 6"



Style S-37 Storz to Rigid Female

Available Sizes:
1½", 2½", 4",
5", 6"



Style S-54

*Storz to Long Handle
Swivel Female*

Available Sizes:
2½", 4", 5", 6"



Style S-54RL

*Storz to Rocker Lug
Swivel Female*

Available Sizes:
2½", 4", 5", 6"



Style SS

Storz to Storz

Available Sizes:
1½", 2½", 4", 5", 6"

Continuous swivel Storz connection available on 4", 5" or 6" at additional charge.

RED HEAD SPECIFICATIONS: Aluminum Storz Adapters shall consist of Storz coupling heads machined from forged 6061-T6 aluminum and adapter components fabricated from seamless extruded 6061-T6 aluminum. All aluminum components shall be hardcoat anodized per MIL-A-8625 Type III, Class 1. Threads shall be blunt start Higbee cut with indicators on adjacent lugs. Part identification shall be permanent and stamped or forged prior to hardcoat. Swivel attachment must be stainless steel ball or 6269-T9 aluminum roller bearings, not swaged. All 4", 5" and 6" adapters shall include a stainless steel external spring-loaded lock. Storz gaskets shall be molded Buna-N rubber. Face gaskets shall be lathe cut ozone free EPDM or synthetic rubber. Adapters and components must meet the requirements of NFPA 1963.

Caps & Plugs

All aluminum caps and plugs from Red Head Brass are made from rugged **extruded 6061-T6** lightweight aluminum and hardcoated to **MIL-A-8625 Type III, Class 1** to resist corrosion and abrasion. All brass caps and plugs are made of **Alloy C83600 ASTM B62, C84400 ASTM B584** or **ASTM B505 (QQ-C-390)** except where noted.

THREADED ALUMINUM CAPS AND PLUGS



Style C

Style P

Available Sizes:
1" thru 6"

Configurations and features:

- Available with or without 12" stainless steel chain.
- Cap available with petcock at extra charge.

THREADED BRASS CAPS AND PLUGS



Style BRC

Style K-BRC

Available Sizes:
1½", 2" or 2½"

Configurations and features:

- Available with or without 12" chain.
- 2½" brass cap and plug machined from high quality forging of Alloy C37700 ASTM B124 (QQ-B-626).



Style BRP

Style K-BRP

BRITISH INSTANTANEOUS CAP AND PLUG

Available Size: 2½" only

- Available in aluminum only.
- Meets BS-336.



Style BIT-C

Style BIT-P

CAM AND GROOVE CAP AND PLUG

Available Sizes: 1½", 2" or 2½"

- Available in aluminum only.
- Handles and pins on cap are 316 stainless steel.
- Meets A-A-59326B (MIL-C-27487).
- Meets ASTM F1122.



Style DC

Style DP



Style C-LH *Long Handle Cap*

Available Sizes:
4" thru 6"

Configurations and features:

- Available with or without 12" stainless steel chain.
- Cap available with petcock at extra charge.



Style SC *Storz Caps*

Available Sizes:
1½", 2½", 4", 5", 6"

Configurations and features:

- **Storz heads** are *forged* 6061-T6 aluminum to [SAE-AMS-QQ-A-367](#) and [ASTM B247](#).
- Includes standard 18" stainless steel cable.
- Pressure/suction seals standard.
- Pressure only seals available on request for pressure only applications.

To order call 800-321-3501

Elbows

Red Head Brass offers a full line of high quality aluminum, brass and Storz elbows.

Style E

Hardcoat Anodized Aluminum Elbow

Available Sizes:

2½" thru 6" in either 30 or 45 degree elbow

Configurations and features:

- Design allows for **any size configuration** including reducers or increasers plus **any thread** desired on the connections. Note: Swivel not available with NPT.
- Machined from **6061-T6 seamless extrusions**, the elbows are assembled with 4 individual threaded parts including a swivel connected using **#316 stainless steel ball bearings** or **6262-T9 aluminum roller bearings**.



- Design allows changes to or repairs of damaged threads without sacrificing the entire unit.
- All four component parts are individually **hardcoat anodized to MIL-A-8625 Type III, Class 1**.
- **NO WELDED COMPONENTS IN THE ELBOW!!**

Style AL-E

Lightweight Aluminum Elbow

Available Sizes:

2½" rocker lug swivel female to rigid male in either 30 or 45 degree elbow.

Configurations and features:

- Elbow body cast from **Alloy A319, AAA319** aluminum and powder coated silver finish.
- Swivels are machined from **6061-T6 seamless extruded aluminum** and hardcoat anodized.
- Swivels connected to body using **#316 stainless steel ball bearings**.



Style SE

Storz to Rocker Lug Swivel Female Elbow

Available Sizes: 4" thru 6" Storz x 6" thread

Configurations and features:

- All **Storz heads** are **forged 6061-T6 aluminum** to **Spec. SAE-AMS-QQ-A-367** and **ASTM B247**. Also complies with **DIN standard**.
- **Stainless steel lock assembly** on all 4", 5" or 6" Storz.
- 30 degree elbow made from tough, lightweight 356-T6.
- Cast elbow has powder coated silver finish.
- All Storz heads and threaded connections are **hardcoat anodized to MIL-A-8625 Type III, Class 1**. **NO PLAIN ANODIZED, PAINT OR POWDER COATED FINISHES ON CONNECTIONS!!! NO CAST HEADS!!**



Style SE-LH

Storz to Long Handle Swivel Female Elbow

- Same features and sizes as style SE except with long handle swivel.

Style SE-SS

Storz to Storz Elbow

Available in 4", 5" and 6" only

Brass Elbows, Wyes & Valves

Style BR-E-25

Brass Elbow

Style K-BR-E

Chrome Plated Brass Elbow

Available Sizes:

2 1/2" rocker lug swivel female to rigid male in either 30 or 45 degree elbow.



Configurations and features:

- Brass elbows are cast from **Alloy C83600 ASTM B62**.
- Brass swivels are machined from high quality forgings of **Alloy C37700 ASTM B124 (QQ-B-626D)**.

Style 272NL

Aluminum Non-Locking Wyes

Available Sizes:

1 1/2" inlet x two(2) 1 1/2" outlets

2 1/2" inlet x two(2) 1 1/2" outlets

Configurations and features:

- 1 1/2" inlet x two(2) 1 1/2" available in NH.
- 2 1/2" inlet x two(2) 1 1/2" available in NH or NPSH.
- Special threads available on inlet swivels.
- Inlet swivels and outlet connections are hardcoat anodized to **MIL-A-8625 Type III, Class 1**.
- Quarter turn ball valves operate easily at all pressures with Delrin ball and seat.
- Handles are non-locking.



Style 281A

Aluminum Hydrant Gate Valve

Available Sizes:

2 1/2" swivel female inlet x 2 1/2" male outlet

Configurations and features:

- High strength, heat-treated, hardcoat anodized, powder coated aluminum body.
- Inlet swivel and outlet machined from **6061-T6 seamless aluminum extrusion** hardcoat anodized to **MIL-A-8625 Type III, Class 1**.
- Features a non-rising stem.
- Full flow 2 1/2" waterway.
- Heavy-duty wedge with crank handle.
- An excellent shutoff to control water hammer.
- Less than 11 turns required to open or close.
- Weight: 4.3 lbs.

To order call 800-321-3501

The Red Head Brass Commitment to Quality and Safety in Wrenches

The Red Head Brass wrench line is yet another example of no compromise of quality in our product line.

All Red Head Brass spanner wrenches are cast from tough, rugged **ALMAG 35 alloy**. They have a **tensile strength of 40 KSI** that meets the requirements of **ASTM GM70B**.

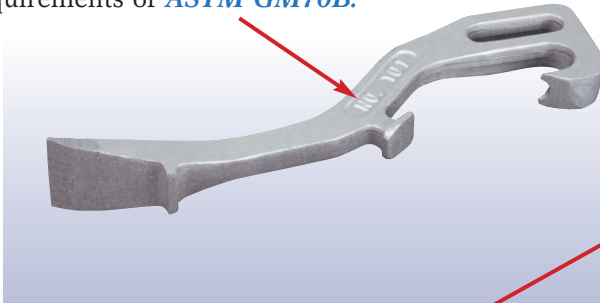

The hydrant wrench handles are chrome plated **carbon steel 1215 ASTM A575 (QQ-S-630)**.

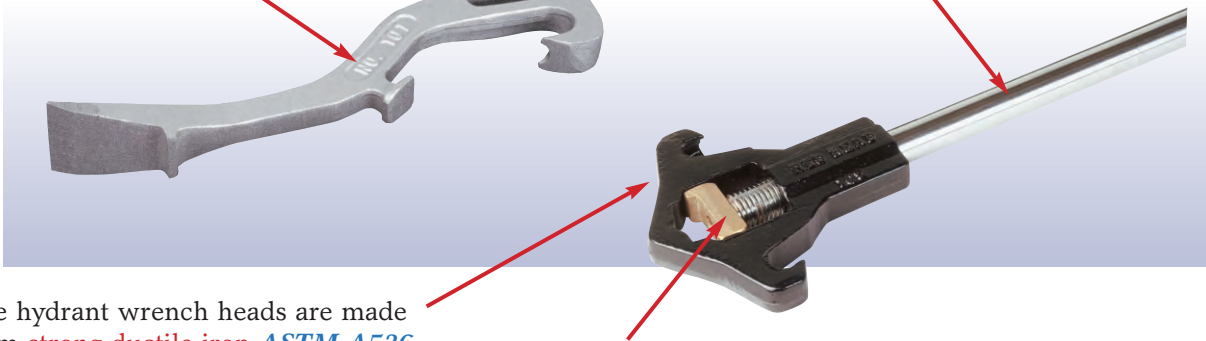

The hydrant wrench heads are made from **strong ductile iron ASTM A536, Grade 65-45-12**.

The jaw on the hydrant wrench is made from tough **manganese bronze Alloy 865 ASTM B147-8A, (QQ-C-390 (C3))**.

Red Head Spanner Wrenches

Style 101

Universal Spanner

- A rugged, all purpose tool.
- Gas cock shut-off located for maximum strength and leverage.
- Fits 3/4" thru 6" rocker lug and pin lug fittings.
- Weight: 8 ounces.
- Length: 10 1/2".

Style 103

Hole Type Spanner

- A compact hole type spanner designed for use on 3/4" and 1" booster hose fittings.
- Weight: 3 ounces.
- Length: 7 1/2".

Style 104

Double End Hole Type Spanner

- For use on 3/4" and 1" booster hose couplings and 2 1/2" hole type fittings.
- Weight: 3 1/2 ounces.
- Length: 7 1/2".



Style 106

Catch-All Spanner

- Fits 3/4" thru 6" rocker lug, pin lug, slot type, or split lug fittings.
- Gas cock shut-off located for maximum strength and leverage.
- Weight: 9 ounces.
- Length: 10".

Red Head Adjustable Hydrant Wrenches

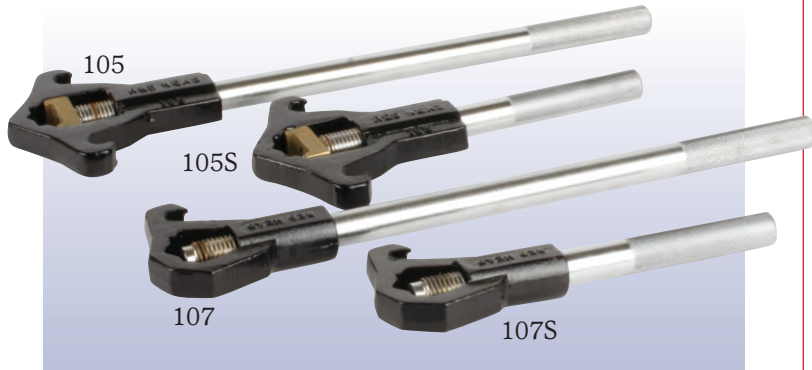

Style 105/105S

Adjustable Hydrant Wrench w/Double Spanner Head

- Wrench will accommodate pentagon heads to 1⁷/₈" and square heads to 1¹/₂".
- Double spanner head is designed to fit 3/4" thru 6" rocker lug or pin lug fittings.
- Jaw is replaceable.
- Weight: 105 - 5 lbs. 105S - 4 lbs.
- Length: 105 - 19 1/2". 105S - 11 1/2".

Style 107/107S

Adjustable Hydrant Wrench w/Single Spanner Head

- Wrench will accommodate pentagon heads to 1³/₄" and square heads to 1¹/₄".
- Single hook spanner head is designed to fit 3/4" thru 6" rocker lug or pin lug fittings.
- Weight: 107 - 4 lbs. 107S - 3 lbs.
- Length: 107 - 18 1/2". 107S - 10 1/2".

Red Head Wrench Holders

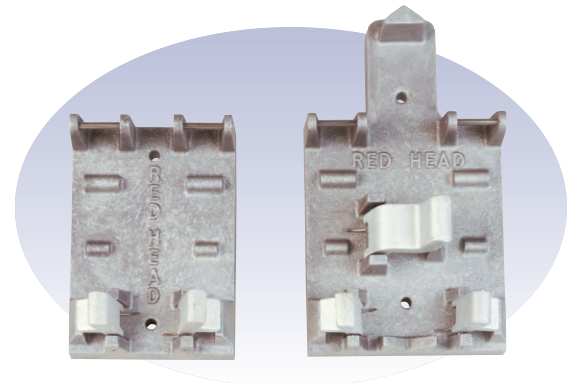

Style 146

Double Holder

- Compact holder for two spanner wrenches.
- Strong stainless steel springs and pin bearings.
- Weight: 1 1/4 lbs.
- Size: 6⁷/₈" x 4⁷/₈" x 2¹/₄".

Style 148

Triple Holder

- Triple holder for one hydrant wrench and two spanner wrenches.
- Long lasting stainless steel springs and pin bearings.
- Weight: 2 1/4 lbs.
- Size: 9³/₄" x 5³/₄" x 2¹/₄".

Red Head Wrench Sets

Style 146-2

Double Holder Set

- Complete with Style 146 holder and two (2) Style 101 spanner wrenches.
- Weight: 2 1/4 lbs.

Style 148-3

Triple Holder Set w/Style 105 Hydrant Wrench

- Complete with style 148 holder, one Style 105 hydrant wrench and two(2) Style 101 spanner wrenches.
- Weight: 8 1/4 lbs.

Style 148-3-7

Triple Holder Set w/Style 107 Hydrant Wrench

- Identical to Style 148-3 except Style 107 hydrant wrench instead of Style 105 hydrant wrench.
- Weight: 7 1/2 lbs.

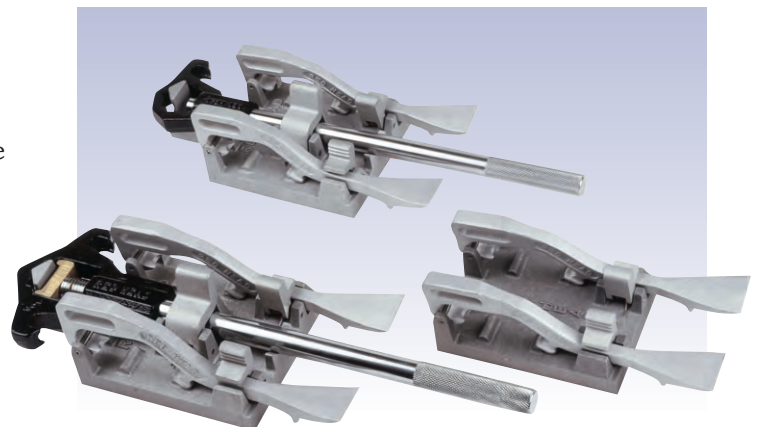

Red Head Storz Spanner Wrenches

Style SW-1

- Designed for sizes 1", 1½", 2", 2½" and 3" Storz.
- Weight: 3½ ounces.
- Length: 10".

Style SW-2

- Designed for sizes 4", 5" and 6".
- Weight: 8 ounces.
- Length: 13".

Style SLW-1

- Designed for use specifically with 4" and 5" locking Storz heads.
- Weight: 8 ounces.
- Length: 11".

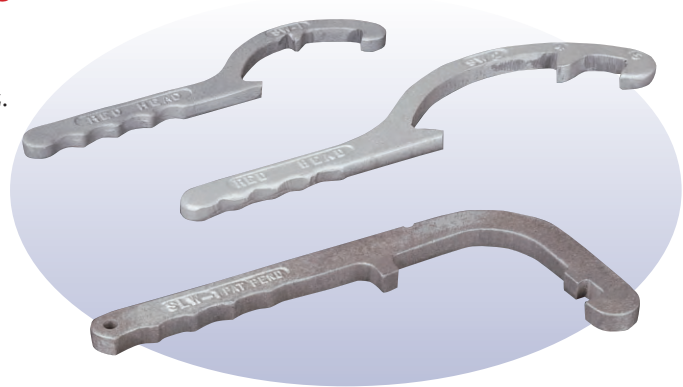

Red Head Storz Hydrant Wrenches



Style SW-3

Adjustable Storz Hydrant Wrench

- Wrench will accommodate pentagon heads to 1⅞" and square heads to 1½".
- Single hook spanner and Storz spanner combination head is designed to fit ¾" thru 6" rocker lug or pin lug fittings plus 4", 5" and 6" Storz heads.
- Bronze jaw is replaceable.
- Weight: 6 lbs.
- Length: 25".

Red Head Storz Wrench Holders and Sets

Style S-146

Double Holder

- Compact holder for two spanner wrenches.
- Strong stainless steel springs and pin bearings.
- Weight: 13½ ounces.
- Size: 4" x 4¾".

Style S-146-1

Double Holder Set w/SW-1 Spanners

- Complete with Style S-146 holder and two (2) Style SW-1 spanner wrenches.
- Weight: 1½ lbs.

Style S-146-2

Double Holder Set w/SW-2 Spanners

- Complete with Style S-146 holder and two (2) Style SW-2 spanner wrenches.
- Weight: 2 lbs.

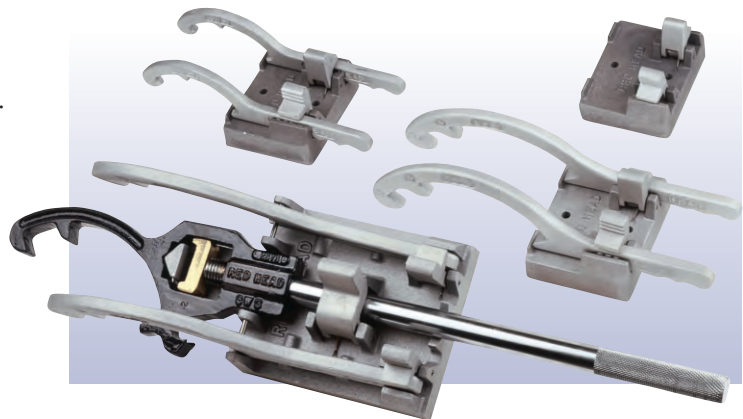

Style S-148-3

Triple Holder Set

- Complete with Style 148 holder, one Style SW-3 hydrant wrench and two (2) Style SW-2 spanner wrenches.
- Weight: 9 lbs.

The Red Head Brass Commitment to Quality and Safety in Gauges

Quality construction is the trademark of all Red Head Brass line and cap gauges.

- All aluminum components are machined from 6061-T6 aluminum seamless extrusions.
- All aluminum components are **hardcoat anodized** per *MIL-A-8625 Type III, Class 1*.
- Each assembly utilizes a 2½" diameter glycerine filled pressure gauge with the following features:
 - Shock resistant one piece cast brass body with stainless steel case and cover ring.
 - High impact lens.
 - Dial face is bright white with black numbering from 0 to 300 PSI in 5 lb. increments.
 - The glycerine protects the gauge from freezing to -40 degrees F and reduces the effects of vibration to allow accurate readings.
- Full scale accuracy +/-1.6%.
- **Made in USA**



Style 153 Threaded Line Gauge

Available Sizes: 1" thru 3"

Configurations and features:

- Line gauge for testing static or flowing pressures in hose or nozzles.
- 1" and 1½" line gauge swivel attached with aluminum piston rings.
- 2½" and 3" line gauge swivel attached with #316 stainless steel ball bearings.



Style S-153 Storz Line Gauge

Available Sizes: 1½", 2½", 4", 5" and 6"

Configurations and features:

- All **Storz Head** connections are **forged 6061-T6 aluminum** to *SAE-AMS-QQ-A-367* and *ASTM B247*.

Style S-154 Storz Cap Gauge

Style 154 Threaded Cap Gauge

Available Sizes:
1½" thru 3"

Configurations and features:

- Cap gauge for testing hose or static pressures on hydrants and trucks.
- Petcock to release pressure.



Style 155 Threaded Encased Line Gauge

Available Size:
2½" only

Configurations and features:

- Line gauge designed for standpipe use, with fully enclosed gauge to prevent damage.
- 2½" swivel attached with #316 stainless steel ball bearings.
- Weight: 4 lbs.

Expanders

Throughout this catalog, we highlight the Red Head Brass commitment to quality. This dedication to offering only the finest products can be found in our line of expanders...the Brute line. We have refined this product offering to two outstanding machines, the hand pump Brute X-Pander portable unit and the electric pump Brute Model 2.

Red Head Brass expanders are precision instruments, made for smooth easy operation. They make every attachment a snug, uniform, secure fit assuring a safe hose and coupling assembly. The Brute machines come complete with operating instructions, including simple diagrams to make each operation easy to understand. We also will provide training at no charge in the use of our expanders at our manufacturing facility in Shreve, Ohio.

Call your distributor for special pricing on the Brute Bundles.

Style Brute X-Pander

Compact Hand Pump Expander

- Designed for forestry services, fire departments, small distributors and ski areas.
- May be used to attach 1" thru 3" couplings.
- Ideal for in-house use or mounted in a service van for field repairs.
- Unit weighs 32% less than our previous hand pump model, requires 50% fewer strokes to expand and 75% fewer strokes to release.
- All-in-one design means fewer parts and no hydraulic connections making the X-Pander our most reliable and service free hand expander ever.
- All current Red Head Brass expansion unit assemblies and replacement parts can be used with the X-Pander.
- Size: 13" W x 17" D x 10" H.
- Weight: 45 lbs.



Style Brute Model 2

Bench Model Electric Hydraulic Expander

- Designed for hose manufacturers and higher volume distributors and fire departments.
- May be used to attach 1" thru 6" couplings.
- 3,000 PSI pump
- 3450 RPM Motor
- 1½ h.p., single phase, 220 v.
- Cylinder - 6" stroke, 4" bore.
- Total thrust - 38,000#.
- Oil Capacity - 9.5 gallons.
- Manually set external pressure relief valve.
- Size: 22" W x 22" D x 16" H.
- Weight: 350 lbs.



NOTE: Red Head Brute expanders *do not* include any expansion unit assemblies. They must be ordered separately. For a complete list of all available expansion units and sizes, contact your Red Head customer service representative.

Expansion Units

Red Head expansion units are compatible with some other manufacturers' expanders. When ordering for machines other than Red Head Brute, specify manufacturer and model.

Repair or replacement parts for Brute expansion units also available, including segments only, segment holders, drawbars, adjusting rings, segment springs, drawbar adapters, etc.

For a complete list of all available expansion units and their sizes, contact your Red Head customer service representative.

When ordering please specify the manufacturer and model number of your particular unit. Also specify the type and size of the coupling you are ordering.

1 1/2" Expansion Unit Assembly



Expansion Unit Assemblies, though shown in illustrations, are not included with any machine and must be ordered separately.

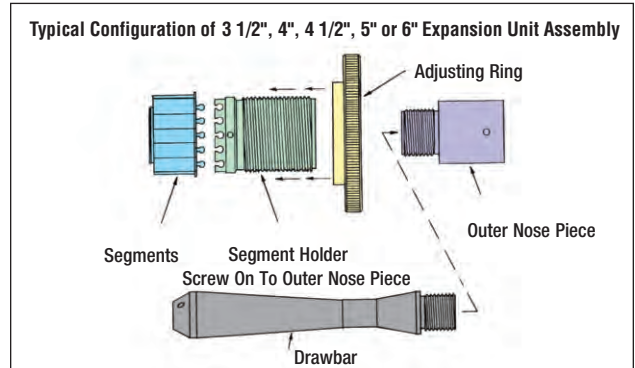
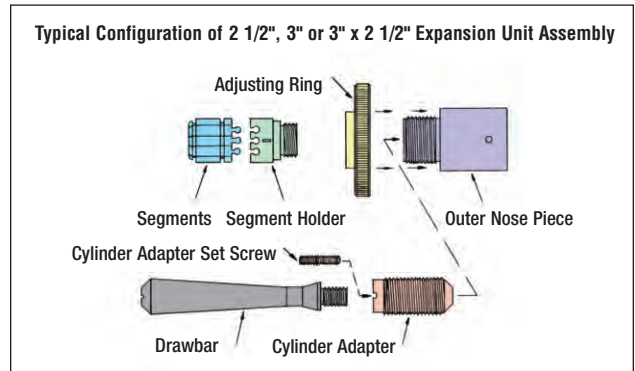
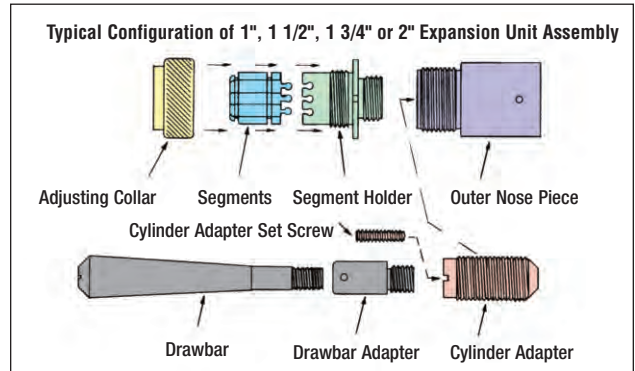

Hose Cutter

- Heavy duty aluminum construction.
- Powder coated for a tough, hard finish.
- Easy and safe to use.
- Makes clean, straight cuts.
- Cuts hose up to 6".
- Ratchet handle raises and lowers steel blade
- Handgrips for easy transporting.
- Size: 20" W x 7" D x 13 1/2" H.
- Weight: 27 lbs.

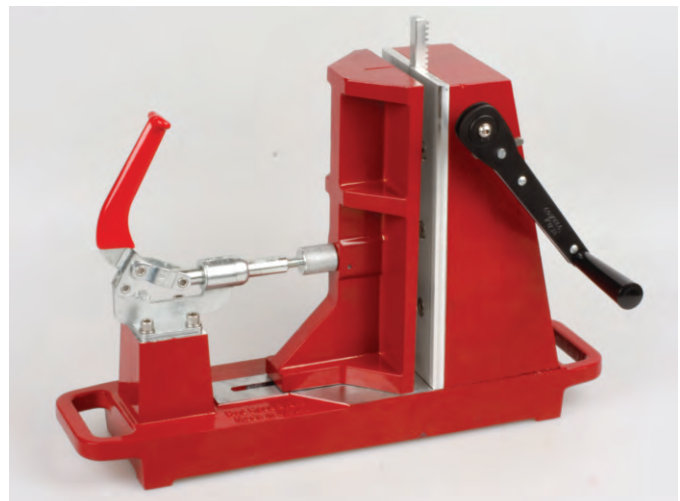

Dry Hydrant Systems

*The Red Head Brass
Commitment to Quality
and Safety in Dry Hydrant
& Water Delivery Systems*

MAXI-FLOW

Red Head Brass has expertly engineered and built all of the complex elements of our line of water delivery apparatus including dry hydrant systems. We take pride in only using the best construction materials to provide you with the high quality you have come to expect from Red Head Brass.

Look for the following quality features:

Aluminum components are hardcoat anodized to **MIL-A-8625 Type III, Class 1. NO PLAIN ANODIZE, PAINTED OR POWDER COATED FINISHES ON CONNECTIONS!!**

Swivel connections are made with **6262-T9 aluminum roller bearings. NO PLASTIC BEARINGS!!**

Adapters, caps, plugs and swivels are machined from tough **6061-T6 aluminum seamless extrusions.** (Exception: the 4½" and 6" dry hydrant caps are cast aluminum.) **NO PLASTIC CAPS OR PLUGS!!**

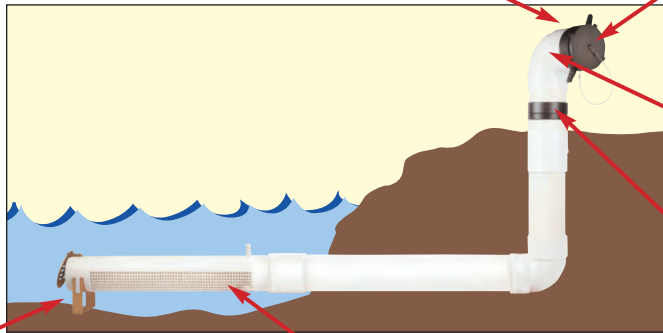

All PVC elbows are heavy duty Schedule 40 to **ASTM D2466.**

Our Style 132-CS dry hydrant swivel allows full 360 degree rotation to allow access from any side.

All **bronze** construction of 6" Style 134 supports resists corrosion indefinitely.

Style 133 strainer made of Schedule 40 PVC pipe to **ASTM D1785.** Outboard end has **brass** clappered end cap on standard 6" underwater strainer.

Each component of the water delivery system is sold separately. You purchase locally the straight sections of PVC pipe needed, saving money and freight. All adapters in the Maxi-Flow system are fitted, secured and vacuum tested to assure vacuum-tight joints. You can count on your Maxi-Flow system for years of trouble free operation. We welcome your calls for technical assistance.

Style 130 Dry Hydrant Plug

Available Sizes:
4" thru 6"

- Includes vinyl coated stainless steel wire rope to secure plug.



Style 132-F Long Handle Swivel Female Dry Hydrant Adapter

Available Sizes: 4" thru 6"

45 degree, 90 degree, or straight 180 degree

- "O" ring seal assures vacuum tight joints.
- Suction strainer, removable for easy cleanout.
- All threads available on swivel except NPT.



Style 131 Dry Hydrant Cap

Available Sizes: 4" thru 6"

- Vinyl coated stainless steel wire rope secures cap.

Style 132 Male Dry Hydrant Adapter

Available Sizes: 4" thru 6"
45 degree, 90 degree, or straight 180 degree

- "O" ring seal assures vacuum tight joints.
- Suction strainer w/removable snap ring for easy cleanout.
- All threads available.



Style 132-CS Dry Hydrant Swivel

Available for 6" PVC only.

- Allows full 360 degree rotation to allow access from any side.
- Adaptable to existing locations.

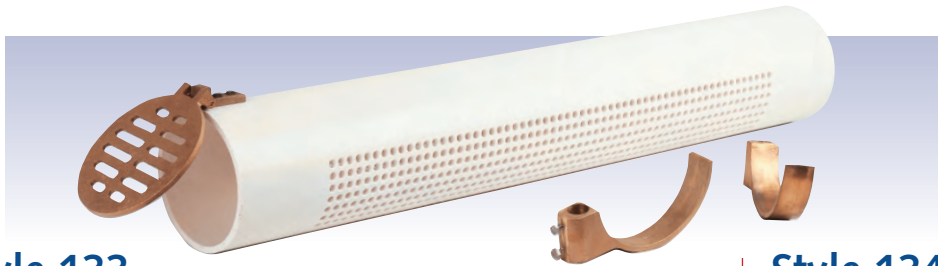

Style 133

Dry Hydrant Underwater Strainer

Available Sizes: 6", approximately 40" long;
and 8", approximately 60" long

- Strainer made of Schedule 40 PVC pipe to **ASTM D1785**.
- 6" - Drilled with 1,140 $\frac{3}{8}$ " holes, each chamfered.
- 8" - Drilled with 1,840 $\frac{3}{8}$ " holes, each chamfered.
- Strainer open area approx. 125 sq. in. (6"), 200 sq. in. (8").
- Both ends machined square.
- Outboard end has Brass clappered end cap on 6"; PVC on 8".
- 8" shipped with 8" x 6" reducing adapter.

Style 134

Dry Hydrant Underwater Strainer Supports

Available Sizes: 6" and 8"

- Cradles and supports dry hydrant intake at proper level.
- 6" is all bronze construction. 8" is aluminum.
- Includes two stainless steel locking screws.
- 1" O.D. pipe or rod is used for support (not furnished).

Style 135

Maxi-Flow Power Jet Siphon

Available Sizes:
4" thru 6" discharge
w/1½" adjustable inlet

- Used to move water through suction hoses between portable tanks using venturi action.



Style 136

Tank Fill Line Adapter

Available Size: 2½" only

- Attaches to folding tank frame.
- Eliminates need for personnel to hold fill line.
- Safe, secure locking action.
- Swivel attached using **#316 stainless steel ball bearings**.
- Weight: 7 lbs.



Our **Maxi-Flow Lo-Level Strainers** use rugged cast aluminum bodies and elbows.
NO WELDED CONSTRUCTION!!

Style 137-HV

Maxi-Flow High Volume Low Level Strainer

Available Sizes: 4", 4½", 5" and 6"

- Capable of flowing **1,700+ GPM**.
- Rotates to suit hose angle/position.
- Drafts to 1¾" depth of water.
- Convenient handle for easy carry.
- Long handle swivel machined from **6061-T6 aluminum seamless extrusions**.
- Swivel is hardcoat anodized to **MIL-A-8625 Type III, Class 1**.
- Swivel attached using **6262-T9 aluminum roller bearings**.
- **#318 stainless steel ball bearings** used in rotating elbow joint.
- High flow replaceable all zinc suction strainer.
- Weight: 23 lbs.

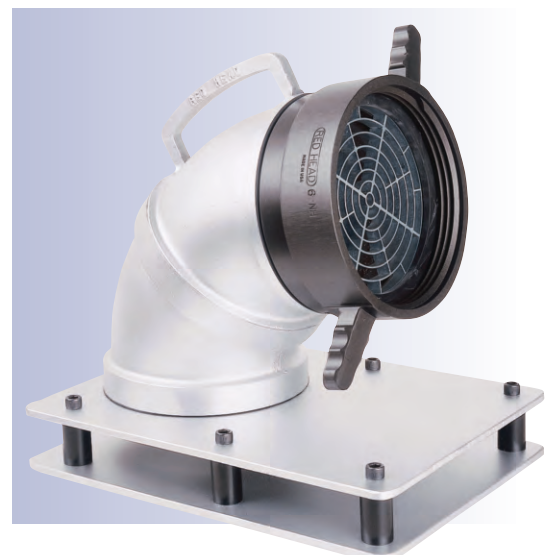

Mounting Plates

The Red Head Brass line of threaded mounting plates is made from tough 6061-T6 aluminum seamless extrusions that has been hardcoat anodized to MIL-A-8625 Type III, Class 1.

Style M

Rigid Male Mounting Plate

Available Sizes: 1" thru 6"



Style FM

Swivel Female Mounting Plate

Available Sizes: 1" thru 6"

- Swivels are attached as follows:
 - 1" thru 2" with 6061-T9 aluminum piston rings.
 - 2½" thru 3½" with #316 stainless steel ball bearings.
 - 4" thru 6" with 6262-T9 aluminum roller bearings.



Style SMP

Storz Mounting Plate

Available Sizes: 4", 5" and 6"

- High tensile aluminum construction with an anodized finish.

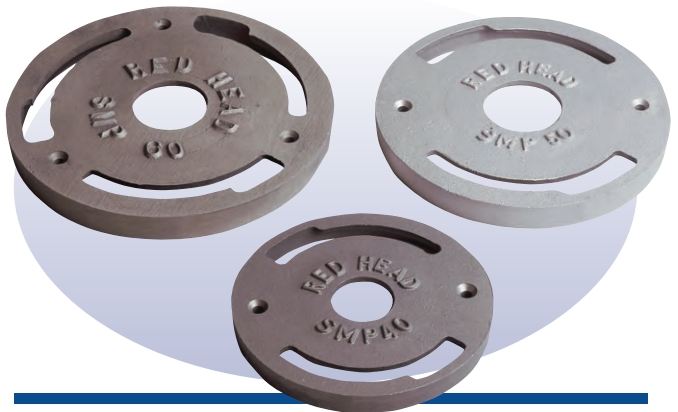

Style NM

Kwik-Tach Mounting Plate

Available Sizes:

Fits female threads from 1½" thru 5".

- Easy one-hand operation.
- Base hardcoat anodized aluminum.
- Assembled with chrome plated brass knobs.
- Can be installed horizontal or vertical.
- Won't mar threads.
- Ideal for mounting nozzles, wyes or adapters.





Gaskets

Available Sizes: 1" thru 6"
 Lathe cut tail gaskets, swivel gaskets and booster gaskets. When ordering, specify if tail, swivel or booster gasket. If tail gasket, specify bowl size or hose O.D. and type of hose; i.e. single jacket, double jacket, rubber covered, soft suction or hard suction.

Storz Molded Gaskets

Available Sizes: 1" thru 6"
 The Buna-N material we use is resistant to most hydrocarbons, oils, gasoline, acids, and greases. All Storz couplings and adapters are supplied with pressure gaskets and caps are supplied with suction gaskets.

Expansion Rings

Available Sizes: 1" thru 6"
 Made from 85/15 red brass for maximum expansion without danger of breaking. Chamfered edge prevents risk of cutting hose. (Machined from globally sourced raw materials)

Bearings and Plugs

#316 stainless steel ball bearings. Used for swivel attachment on rocker lug couplings 3" to 3½", long handle couplings 2½" thru 3½" and all swivel adapters 2½" thru 3½". (Globally sourced)

6262-T9 aluminum roller bearings. Used for swivel attachment on all fittings 4" thru 6".

Bearing retainer plugs for ball bearings or roller bearings.

Camlock Kits

Replacement arms, pins and rings for Cam and Groove couplings and adapters.

Lam-n-Sole

Safety Insoles

Shaped, flexible .020" stainless steel with ¼" thick foam latex pad for comfort. Slip into boots, work shoes, dress shoes, even jogging shoes to protect your feet from hazards such as nails, broken glass, sharp metal and barbed wire.



SIZE EQUIVALENT CHART			
Code Letter	Work Shoe Size	Rubber Boot Size	Boot Size
AA	6		.4
A	7		.5
B	8		.6
C	9		.7
D	10		.8
E	11		.9
F	12		1.0
G	13		1.1
H	14		1.2
I	15		1.3

Order by code letter.

Style 109

Expansion Ring Removal Tool

Rugged heavy-duty expansion ring removal tool. Use on sizes 1" thru 6". Replacement pins available.



Length: 18"
 Weight: 4 lbs.

Style 139

Basket Strainer

Available Sizes: 2½" thru 6"
 Base is made from 6061-T6 aluminum seamless extrusions hardcoat anodized to MIL-A-8625 Type III, Class 1. Base has lugs and holes for rope connections. Baskets are ¼" x ¼" square zinc-plated mesh for high capacity intake.



Style 140

Barrel Strainer

Available Sizes: 5" and 6" with a rope eye attached

Tough, high volume barrel strainer made from 6061-T6 lightweight aluminum and hardcoated to MIL-A-8625 Type III, Class 1 to resist corrosion and abrasion. Drilled with 720, ⅜" diameter holes. All three parts are threaded for easy removal to repair or change threads.



Style 690

Adapter Strainer

Designed for suction adapters. Sizes 2½" and 3" are plastic; all others thru 6" are tough die cast zinc.



Nozzles

Red Head nozzles are machined from 6061-T6 aluminum seamless extrusions. The finish is a *polished hardcoat* anodize to *MIL-A-8625 Type III, Class 1* except SS-1, DP-2, & DP-1, which are hardcoat anodized but not polished.

Style DT-1 Deluge Tip

Configurations:

Length: 9"
Base: 2 1/2"
Orifice: 1 1/2"



Style SS-1 Stream Straightener

Configurations:

Length: 3"
Inlet: 2 1/2"
Outlet: 2 1/2"



- Use with all large volume discharge devices for increased range and effective reach.
- Complete with stream straightener fins.

- Red Head Brass **discharge pipes** are designed for use on all monitors.
- Maximum flow rate of 1,750 GPM.
- Two sets of stream straightener fins to insure maximum reach and solid streams.

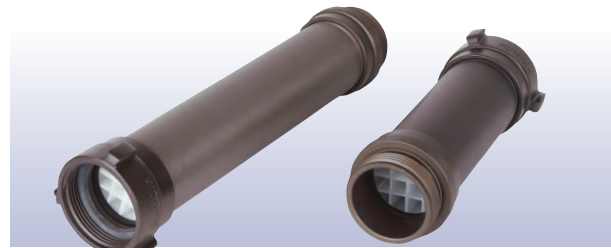

Style DP-2 Discharge Pipe

Configuration:

Length: 16"
Inlet: 2 1/2"
Outlet: 2 1/2"

Style DP-1 Discharge Pipe

Configuration:

Length: 11"
Inlet: 2 1/2"
Outlet: 2 1/2"

Stacked Tips



Style	Length		Base	Middle	Middle 2 (Quad)	Top
ST-2 DOUBLE STACK TIP	6 3/4"	Threads	1 1/2" NH			1"
		Orifice	1 5/16"			1/2"
		Opt. Orifice	1 1/8"			1/2"
ST-3H TRIPLE HANDLINE STACK TIP	8 1/2"	Threads	1 1/2" NH	1 1/2" NH		1 1/4" NPSH
		Orifice	1 1/4"	1 1/8"		1"
ST-3D TRIPLE DELUGE STACK TIP	12"	Threads	2 1/2" NH	Underwriters PP		1 1/2" NH
		Orifice	1 3/4"	1 1/2"		1 3/8"
ST-4 QUAD DELUGE STACK TIP	17"	Threads	2 1/2" NH	2" NH	Underwriters PP	1 1/2" NH
		Orifice	2"	1 3/4"	1 1/2"	1 3/8"

Smooth Bore Tips



Style SB-1

Smooth Bore Tip

Configurations:

Length: 4 1/2"
Threads: 1"
Orifice: 3/8"

Style SB-2

Smooth Bore Tip

Configurations:

Length: 6"
Threads: 1 1/2"
Orifice: 7/8", 1", 1 1/8" or 1 1/4"

Style SB-S

Smooth Bore Tip

Configurations:

Length: 3"
Threads: 1 1/2"
Orifice: 5/8" or 7/8"

Style SB-L

Leader Line Smooth Bore Tip

Configurations:

Length: 6"
Threads: 1 1/2"
Orifice: 1 1/8" or 1 1/4"

Thread protector on lead thread.

Hy-D™

- Revolutionary Hydrant Mass Decontamination Nozzle.
- Patent Number: D 557,376 S.
- Available in kit with hydrant gate valve, 30° low pressure elbow, Style 105-S hydrant wrench, and HY-D™.
- Simple. Compact. Effective.
- Listed on Department of Homeland Security responder knowledge base.
- Easily attaches to hydrant or side of fire truck.
- Provides fast and thorough mass shower decon.
- Single person installation.
- Low water usage. Minimizes runoff.
- Needs no repeated maintenance.
- **Inexpensive.**
- Approved on the FEMA Standard Equipment list. May be purchased with FEMA grant funds.
- Hy-D 4 lbs. Kit 13 lbs.



Hy-D™ in Action



FAQs – Made in USA

Red Head Brass Checklist to meet FTC “Made in USA” guideline of “all or virtually all”

Questions to ask a supplier: *Red Head Brass*

- Are all aluminum extrusions fabricated at a US facility? If not 100%, what % is imported into the US? • Yes 100% PA
- Are all raw forgings fabricated at a US forging house? If not 100%, what % is forged outside the US? • Yes 100% CT
- Are all raw castings fabricated at a US foundry? If not 100%, what % is cast outside the US? • Yes 100% OH, IN, PA, MI
- Are all machining operations performed at US factories or machine shops? If not, what % is machined outside the US? • Yes 100% Red Head, OH
- Are hardcoat anodizing and other finish operations performed at US operations? If not, what % is finished outside the US? • Yes 100% Red Head, OH, PA
- Is all final assembly done in the US? If not, what % is assembled outside the US? • Yes 100% Red Head

Are all 6061-T6 extrusions equal in quality? The short answer is no. Our US based suppliers have pointed out that imported extrusions often barely meet the 6061 specification from a metallurgical requirement. Also, differences in quenching methods can allow for a difference in the grain structure of the final product. Imported extrusions have also been found to be seamed (port hole extrusions) as opposed to seamless. Red Head Brass uses only seamless 6061-T6 extrusions from our aluminum vendor in Pennsylvania.

Terminology such as “we buy only from US sources” does not always mean US product. The “US source” may be a US-based broker that is bringing into the US imported raw materials and/or products.

When you purchase a high quality product from Red Head Brass, you not only support the dedicated members of the Red Head family, but hundreds of other American workers at the US mills, foundries, forging houses, machine shops and finishers that we support with our business. Together we combine to produce what we believe are the highest quality and safest products available.

It is with great pride that our products are labeled “Made in USA.”

Customer Service



Terrie

Melody

Engineering



Jarret

Joe



The following charts list many commonly used threads. Red Head Brass manufactures products with any thread required. In fact, our special thread codes number in excess of 2,200 different thread configurations. Call Red Head Customer Service for assistance.

Commonly Used Threads

Note: NPT threads are not available on female swivels.

SIZE	NATIONAL STANDARD NH (NST)		STRAIGHT IRON PIPE NPSH (IPT)		GARDEN HOSE GHT		BRITISH STD PIPE BSP		NEW YORK CORP NYC		NEW YORK CITY FD FDNV		PACIFIC COAST PCT		CHICAGO HOSE		CHICAGO FIRE DEPT CFD		NAVY HOSE	
	ODM	TPI	ODM	TPI	ODM	TPI			ODM	TPI	ODM	TPI	ODM	TPI	ODM	TPI	ODM	TPI	ODM	TPI
3/4"	1.375	8	1.035	14	1.062	11.5	1.041	14					1.062	11	1.081	11.5				
1"	1.375	8	1.295	11.5			1.309	11			1.660	8	1.312	11.5	1.295	11.5				
1 1/2"	1.990	9	1.878	11.5			1.882	11	2.093	11	2.100	8	2.100	11	1.946	11.5	1.933	11.5		
2"	2.515	8	2.352	11.5			2.347	11	2.547	11	2.530	8	2.550	10	2.522	8				
2 1/2"	3.068	7.5	2.841	8			2.960	11	3.000	8	3.030	8	3.035	7.5	3.043	7	2.990	7.5		
3"	3.623	6	3.470	8			3.460	11			3.630	8								
3 1/2"	4.243	6	3.970	8			3.950	11			4.070	8					4.052	8		
4"	5.010	4	4.470	8			4.450	11			4.610	8	4.828	6			5.011	4	4.908	6
4 1/2"	5.760	4	4.970	8							5.800	4					5.761	4		
5"	6.260	4					5.450	11			6.260	4					6.260	4		
6"	7.025	4					6.450	11			7.025	4					7.025	4		

Abbreviation for Tapered Iron Pipe Thread is NPT (National Pipe Tapered) or TIPT. NPT threads are not available on female swivels.

Standard threads for Red Head are National Standard (NH or NST), Straight Iron Pipe (NPSH, IPT or SIPT), Garden Hose (GHT) and Tapered Iron Pipe (NPT, TPT or TIPT).

OTHER U.S. STANDARD 2 1/2" HOSE THREADS

CITY	IDM	TPI
Buffalo, NY	3.0625	8
Cincinnati, OH (New)	3.0580	6
Cleveland, OH	3.0781	8
Denver, CO	3.0920	8
Detroit, MI	3.1250	7.5
Omaha, NE	3.0781	8
Phoenix, AZ (Old)	3.0620	6
Pittsburgh, PA	3.0625	6
Salt Lake City, UT	3.2500	6
Toledo, OH	3.0000	8

OTHER CANADIAN STANDARD 2 1/2" HOSE THREADS

		ODM	TPI
AMA	Alberta Mutual Aid	2.990	8
BCT	British Columbia	3.000	8
CSA	Canadian Standards Assoc.	3.125	5
QST	Province of Quebec Std.	3.031	7
WCT	Western Canada Fire Under	3.250	6
NOVA	Nova Scotia- Zone 1	3.234	5
QMT	Quebec/Montreal Combination	3.031	7

How to determine your thread dimensions if Leaf Thread Gage and O.D. Tape are not available.

1. Take a strip of paper about 1" wide and long enough to completely circle the male thread.
2. Wrap this paper around the male thread snugly, making sure it is against the shoulder all the way around. At some point where the strip overlaps, pierce through both of the overlapped papers with a pin. (Fig. 1)
3. Then with the thumb, press the paper firmly against the threads around the entire circumference to leave an impression of the threads. (Use the end of a pencil if necessary to bring out the edge of the thread onto the paper.) (Fig. 2)
4. Remove the paper strip and circle each pin prick with a pencil.
5. The distance between these two points divided by 3.1416 equals the ODM (Outside diameter of the male).
6. The impressions on the paper give the number of threads per inch (TPI). Both the ODM and TPI are needed. (Fig. 3)
7. You may also use this same method to determine the outside diameter (OD) of a hose.

Note: Do not measure a badly worn thread. If only a worn thread is available, send the male fitting to Red Head for an accurate determination of the thread dimensions.

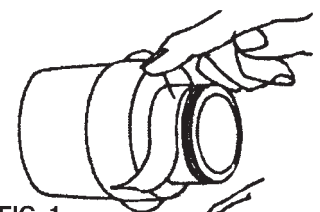

FIG. 1

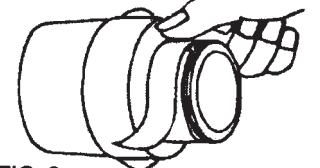

FIG. 2

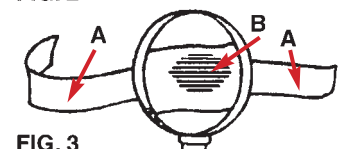

FIG. 3

What is the "DIN Standard" referred to in the Storz pages of this catalog?

DIN is an abbreviation for the *Deutsches Institut für Normung e. V.*, an institution of trade and industry responsible for the preparation of National Standards in Germany. Storz fittings were patented in Europe by Carl August Guido Storz over one hundred years ago and are now in use worldwide. DIN publishes standards for the design of these Storz fittings. Although the catalog refers to the "DIN Standard," there are actually a number of standards that apply, one for each size and type of Storz coupling or adapter. All of the Standards for aluminum fittings are in the DIN 143xx series. For instance, DIN 14303 covers Size B (75mm) Aluminum Delivery Hose Couplings for Fire Brigade Use. This standard specifies that the Storz head be a DIN 1725 Part 1 Aluminum forging. Cast aluminum Storz fittings can be used for non-firefighting, lower pressure applications such as agriculture. In the interests of the safety of the "Fire Brigade," all Storz couplings, adapters and caps supplied by Red Head Brass are made from aluminum forgings.

What is the difference between a forging and a casting?

Forgings are manufactured by pressing metal under great pressure into parts that, as a result, have high strength. The metal is typically heated, but not melted, before forging. In the casting process, the metal is melted before going into a mold. The metal poured into the mold solidifies as it cools. The control of the molten metal temperature is critical. Likewise, the quality of the metal being melted must be controlled so that no impurities get into the molten metal. Any gases that are trapped can create porosity as the metal cools. Low casting temperature and impurities, such as sand or slag, can cause imperfections known as cold shots. Metallurgically, a casting has no grain flow or directional strength. A casting can contain many unseen defects. Forgings, on the other hand, have no internal voids that can cause unexpected failures. The grain structure of a forging is oriented to part shape for greater strength. A forging has greater density. In general, forgings are seen as having a higher integrity and greater reliability than castings.

What is "Hardcoat Anodize" and why do I need it?

Not all anodizing is the same. "Hardcoat Anodize" is very specific type of anodize that gives aluminum parts greater abrasion and corrosion resistance than that provided by the more conventional plain anodize processes. It is sometimes referred to as "Alumilite Hard Coat," "Martin Hard Coating," "Hard Anodizing" or "Hard Coating." The coating is a hard aluminum oxide that is formed by the electrochemical reaction of aluminum with oxygen. It is chemically bonded to the aluminum. Hard Anodic Coatings are defined by Military Specification MIL-A-8625, Type III, Class 1. In order to meet this specification, the coating thickness must be held to .002" +/- 20%, pass the abrasion resistance requirement found in the specification, and be routinely tested to the parameters to insure quality. Plain, or conventional, anodize has no such requirement for thickness or wear resistance. Other coatings, for instance paint or powder, likewise have no such requirement for abrasion resistance. The threaded and non-threaded couplings and adapters used in firefighting greatly benefit

from the abrasion and corrosion resistance provided by Hardcoat Anodize. It is the specification Red Head Brass follows in manufacturing its quality aluminum products.

What is a "Higbee"?

A "Higbee," also known as a Quick Start Thread, is a modification to the first thread of a hose thread. The thread is machined back from the end until the cross section of the thread is full, in other words looks like a fully formed triangle. Mating threads go together and start quickly. There is no partial, or thin, thread to be rolled over and jam the connection. The full strength of the thread is available as soon as mating threads are connected. On Rocker Lug parts, there is a notch in the lug adjacent to the Higbee to help locate the Higbee for ease of assembly. This is especially important for internal threads where the Higbee cannot be easily seen. NFPA 1963 requires a Higbee on NH threads. Taper Pipe Thread, NPT, does not get a Higbee.

Will Storz fittings from Red Head Brass mate with Storz fittings from other manufacturers?

Simply put, as long as they are the same size, they should. Red Head Brass manufactures Storz fittings to meet the established dimensional standards. As long as the Storz fittings from other manufacturers meet these standards, the fittings will mate. The 4" and 5" Storz connections, for example, are included in NFPA 1963. However, there are numerous sizes of Storz fittings available. Some are only metric sizes. Others are combination English/Metric sizes. Those sold domestically are very specific sizes for the US market and are usually marked with the nominal size in inches. They may also be marked with both English and Metric units. Red Head Brass currently offers 1-1/2" (38mm), 2-1/2" (65mm), 4" (100mm), 5" (125mm) and 6" (150mm) Storz fittings.

Why is "Seamless" better than "Structural" extruded aluminum for firefighting applications?

Although they may look the same, structural and seamless tube are two distinctly different products. The two products are extruded by two different techniques. "Seamless" is extruded from a hollow billet by the die and mandrel process or from a solid billet on a piercer press. In either case, the wall of the extruded tube never separates as the shape is extruded. This results in a uniform structure with predictable strength throughout. Structural tubing, on the other hand, is produced by a bridge die or port hole die. The mandrel that makes the inside diameter of the tube is supported by webs. As the metal passes through the die it is separated by the webs. As the metal exits the die a mechanical bond, or weld, is created. The grain structure is often different where the weld seams are located. The weld seams run down the entire length of the tube. The seams can often be seen after anodizing. The seams take on a different color than the surrounding metal. When viewed on end, the seams appear as spokes on a wheel. There are no standard industry guidelines for weld seam quality and each producer establishes their own internal criteria. There are no published burst pressure ratings for structural tube. Manufacturers of structural tubing do not recommend its use for pressure applications. Test pressures for fire hose couplings and adapters can be in the 1000-1200 psi range. For its quality hose couplings and adapters, Red Head Brass machines these critical components from seamless extruded 6061-T6 aluminum exclusively.

Are there different types of Storz gaskets?

In general, there are two different types of Storz gaskets, namely Pressure gaskets and Suction gaskets and they operate in different ways. It is important, when ordering, to specify the application so that the correct coupling or adapter, with the proper gasket, is supplied. The gaskets, although similar, are generally not interchangeable. The Pressure gasket has a lip, or flap, that is open to the inside, facing the water. As the line is charged, the lip pushes out tighter and tighter against the lip of the gasket in the mating coupling to make a waterproof seal. The coupling torque to assemble two mating pressure couplings is small so that the couplings can easily be connected. Water may leak out until the pressure in the line rises to push the flaps together. On the other hand, Suction gaskets have a flap on the outer rim, facing the outside. The coupling torque to assemble mating suction couplings is higher so that these flaps on mating couplings are pressed together initially, sealing out the outside air, so that the draft can be started. As the suction increases, the flaps are pulled together even tighter. Because of the higher connection torque, wrenches may be needed to assemble Storz Suction fittings. Pressure gaskets are black in color. Suction gaskets are grey. NFPA 1963 requires that Suction gaskets be installed in Storz Caps.

What is the difference between "NH", "NST", "NPSH", "IPT" and "NPT" threads?

"NH", or National Hose, thread is the thread that has become the standard thread used in firefighting today. The threads specified in NFPA 1963 are "NH". This thread was previously known as "NST" or National Standard Thread. "NPSH", or National Pipe Straight Hose, is slightly smaller in diameter and has more threads per inch than the same nominal diameter "NH" thread. "NPSH" thread is sometimes referred to as "IPT", or Iron Pipe Thread. "NH" and "NPSH" threads are not interchangeable. "NH" and "NPSH" threads are straight threads and require a gasket for sealing between mating threads. "NPT", or National Pipe Tapered, is the thread most commonly found in plumbing applications. Being tapered, the seal between mating threads is made by squeezing the threads together. No gasket is used. "NPT" and "NPSH" threads are similar in diameter and threads per inch.

Why aren't tapered pipe threads (NPT) available in swivels?

The typical coupling consists of three main components; male, band, swivel. The swivel's job is to bring together the male and the band, squeezing a gasket between them, sealing the water path. With straight threads, like NH or

NPSH, the swivel turns on the male as far as necessary to make this seal. However, NPT threaded components seal by jamming the mating threads as they are tightened. No gasket is used. The turns required to tighten may vary. If NPT threads are used in a coupling, the end of the male may not stop at the correct place in the swivel. The male can be tight into the swivel but, even with a gasket, it may not seal against the band. This would allow water to leak out of the joint. Thus, NPT threads are not available in swivels. However, a coupling set with a NPT male and a NPSH swivel can work. NPSH thread is the straight version of NPT thread. A NPT male will screw into a gasketed NPSH swivel and seal against the band, provided the end of the male is cut square.

What kind of maintenance should be done on Couplings and Adapters?

The NFPA publishes an excellent Standard, *NFPA 1962 Standard for the Inspection, Care, and Use of Fire Hose, Couplings, and Nozzles and the Service Testing of Fire Hose*, that covers this subject very well. Red Head highly recommends that the Standard be followed. Chapter 6 of the Standard pertains to Nozzles, Couplings, and Gaskets but the recommendations in the chapter apply equally well to appliances, such as elbows, wyes, and adapters, both threaded and non-threaded. In general, NFPA 1962 recommends that these type items be inspected after each use and at least annually. The annual Service Testing of hose is a good time to include these inspections. Some of the items the inspection should look are:

- Waterway clear, no obstructions.
- Threads not damaged.
- Swivel rotates freely, bearing plug and bearings in place.
- No excess corrosion.
- Gaskets in place and in good condition.
- Clamp bolts on LDH coupling collars in place and tight.
- Storz head lock levers, if so equipped, in place and operating freely.
- Hose not slipping out of the coupling.

In the case of connections of components made of dissimilar metals, for instance brass and aluminum, the standard recommends that they be disconnected and inspected quarterly for corrosion. If the inspection reveals problems, the item should be fixed immediately, taken out of service and fixed, or replaced as necessary.

Red Head Brass, LLC



643 Legion Drive • P.O. Box 566 • Shreve, Ohio 44676 • Email: sales@redheadbrass.com • www.redheadbrass.com
Voice 330-567-2903 • Fax 330-567-2947 • Toll Free in U.S. and Canada 1-800-321-3501